



Smart solutions.
Strong relationships.

LV BRAKE MOTORS



Kibosh

The most reliable range of brake motors



Crompton Greaves (CG) is part of the US\$ 4 bn Avantha Group ,a conglomerate with an impressive global footprint. Since its inception CG has been synonymous with electricity.

The company has retained its leadership position in the management and application of electrical energy.

Today ,Crompton Greaves is one of the largest private sector enterprises. It has diversified extensively and is engaged in designing ,manufacturing and marketing technologically advanced electrical product and services related to power generation ,transmission and distribution ,besides executing turnkey projects. The company is customer-centric in its focus and is the single largest source for a wide variety of electrical equipments and products.

CG employs more than 10000 people in 21 countries. With several international acquisitions. Crompton Greaves is fast emerging as a first choice global supplier for high quality equipment through its business groups viz;

Power System: Transformer ,Switchgear ,Power Quality. Engineering Projects.

Industrial Systems:Motors,Alternators,Drives,Railway Signaling,Stampings.



AVANTHA
GROUP COMPANY

Crompton Greaves Ltd

As one of the world's leading engineering corporations, CG provides end-to-end solutions, helping its customers to use electrical power effectively and to increase industrial productivity with sustainability. CG was established in 1937 in India; and, since then the company has retained its leadership position in the management and application of electrical energy.

CG is leading manufacturer of electric motors, with motor solutions, which benefits a wide range of customers. Our products are used in almost every industrial application including general manufacturing, petrochemicals, food processing, Pharmaceuticals where they drive fans, pumps, compressors conveyors, lifts and cranes, amongst other things.

Our core competence lies in our design facility conforming to the international quality standards. We make continuous effort, to bring out the latest, most advanced product into marketplace.

We continuously add many new services, features and introduce new solutions so as to ensure complete customer satisfaction.

Kibosh Brake Motors:

CG offers Kibosh brake motors, the most reliable range with highly competitive delivery time. Kibosh brake motors are designed to serve various braking applications like crane, hoists, rolling mills, wind mills, elevators etc.

Kibosh covers ac squirrel cage induction motors with output from 0.75 kW to 30 kW in frame sizes NG80 to ND200L cast iron & aluminum body construction.

Design and Construction:

A Brake Motor is a combination of an AC induction motor and a disc type fail safe electromagnetic brake unit. It consists of following:

- 1) A.C Induction Motor.
 - 2) Rectifier Unit.
 - 3) Electromagnetic Brake Unit.
 - 4) Cooling fan at non driving end.
- a) Brake: All standard Brake motors are provided with external DC spring applied fail safe brake "Normally On" which is having following excellent features:

- 1) Power saver
- 2) Fast engagement and fast dis-engagement
- 3) Low heating of brake
- 4) Enhanced liner life

- 5) Dust protecting seal
- 6) Compact size
- 7) Rust protection to all metal parts
- 8) Coil with F class insulation

Because of all above excellent feature, DC fail safe brake provide following advantage during its operation:

- Lower heating of the brake
- Very fast engagement of the brake.
- The booster coil provides very fast release of the brake

Overload capacity: Motors can withstand the 1.5 rated current for 2 minutes without suffering damage. This feature makes the motor suitable for severe duty applications.

Life of motors: Kibosh Brake Motors are designed and manufactured with carefully selected and tested insulating materials to ensure long services. The life of the motors mostly depends upon the life of insulating material.

Over speed: All 4,6,8 pole motors are designed for withstanding an over speed of 2.5 times rated synchronous speed or 2000 rpm whichever is less.

Operation:

Brake motors provide the means of slowing or stopping the driven equipment effectively and safely in a very short time period, the brake unit (DC or AC) are single disc type, mounted on non-driving end of the motor. They are spring applied electrically released unit which provide fail-to-safe operating characteristics such that on interruption, or failure of the power supply the brake will engage and interrupt the load.

With DC brake the brake coil is fed via a rectifier in the motor terminal box for frame size 80 to 200, AC brakes are connected directly to the motor terminal and offered on request.

Kibosh Special Features:

- Brake Kit:- Every CG make safe area motor, up to 132 frames, is having the unique feature being able to be modified to a brake motor by using brake kit in approximately 30 Minutes.

- Multi Mount:-

(Aluminium motor range up-to 7.5 kW)- By simply changing the position of feet, user is able to convert right left or top terminal box position and by changing the standard end shield user can change it for flange or face version.

- Provide high starting torque with low starting current
- Very fast engagement of brakes
- DC and AC brake options.
- No separate terminal box for rectifier and DC supply required.
- Lower maintenance and enhanced liner life
- Proven reliability with long life.

Reference Standards

Standards	Description
IEC 60034-1:2010	Rotating electrical machines - Rating & Performance
IEC 60034-30:2008	Rotating electrical machines - IE Code for Efficiency Classes
IEC 60034-2-1:2007	Rotating electrical machines - Determination of Losses & Efficiency
IEC 60034-5:2006	Rotating electrical machines - Degrees of protection
IEC 60034-9:2007	Rotating electrical machines - Noise Limits
IEC 60034-14:2007	Rotating electrical machines - Vibration Limits
IEC 60072-1:1991	Rotating electrical machines - Dimensions
IS 1231:1974	Rotating electrical machines - Dimensions foot mounted
IS 2223-1983	Rotating electrical machines - Dimensions flange mounted

Kibosh Brake Motors

Range	
Output	0.55 kW to 30 kW
Frames	80 to 200L
Poles	4, 6, 8

Specification	Standard Product		Option
	Frame Sizes	80 to 200	
Enclosure	IP 55		IP56, IP65
Mounting Option	Foot (B3)		Flange (B5), Face (B14) and combination on request
Terminal Box Position	Top		Left Hand side (LHS) / Right hand side (RHS)
Voltage	2.2 kW and below 415V	⋈	Other on request
	3.7 kW and below 415V	△	
Frequency	50Hz		60Hz
Cooling	IC411		IC410
Lubrication	Greased - for - life		Frame 160 to 200 online greasing
Insulation	Class F		Class H
Temperature Rise	Class B		--
DC Brake	Refer Brake Details		Ac brake
Paint Shade	RAL 9005		As per customer

The above specification and options give a brief summary of features available for the Kibosh brake motors. For full listing of optional features, please contact CG sales.

Brake Motor Selection Guidelines:

Before selecting a brake motor it is recommended to check following points:

- 1) Application details.
- 2) Output and Speed.
- 3) Ambient temperature and special environment factor.
- 4) Mounting method.
- 5) Duty Cycle with number of starts/stops per hour.
- 6) Load GD refer to the motor shaft.
- 7) Braking torque required.
- 8) Maximum permissible stopping time.
- 9) Any other special feature required.

Quality:

Stringent quality procedures are observed from first design to finished product in accordance with the ISO9001 documented quality systems. All of our factories have been assessed to meet these requirements, a further assurance that only the highest possible standards of quality are accepted.

Dimension Drawing - Three Phase Foot Mounted Aluminium Kibosh Brake Motors

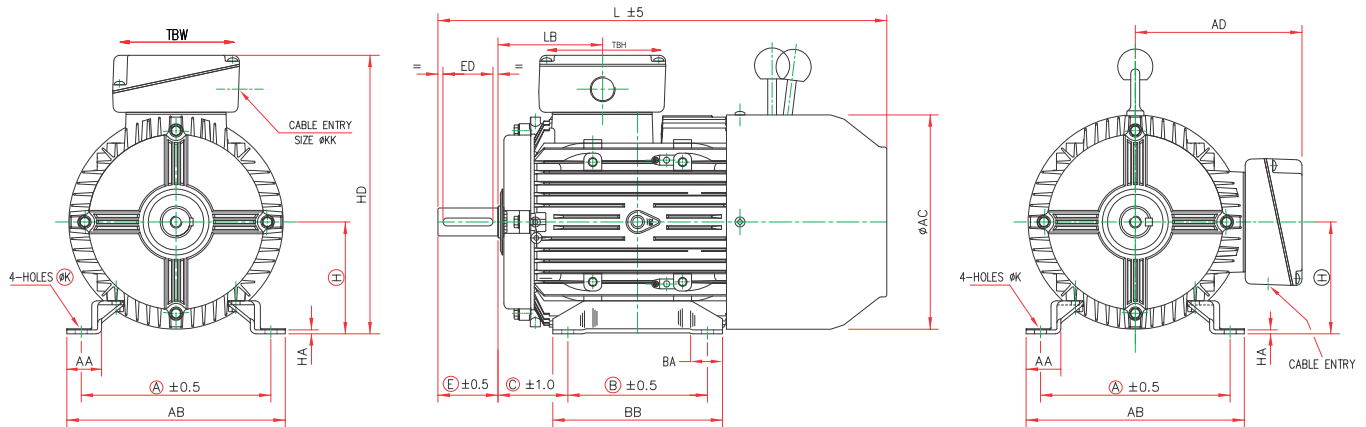

GENERAL (ALUMINIUM CONSTRUCTION)													Terminal Box		
Type	A	B	C	H	K	L	AA	AB	AC	BB	HA	HD	TBW	TBH	KK
GD80	125	100	50	80	10	345	27	157	160	127	4	212	103	103	20
GD90S	140	100	56	90	10	400	28	164	178	150	4	225	103	103	20
GD90L	140	125	56	90	10	400	28	164	178	150	4	225	103	103	20
GD100L	160	140	63	100	12	462	28	184	199	170	4	254	106	106	20
GD112M	190	140	70	112	12	485	35	218	215	170	4	279	127	127	25
GD132S	216	140	89	132	12	551	38	242	255	208	5	320	127	127	25
GD132M	216	178	89	132	12	551	38	242	255	208	5	320	127	127	25

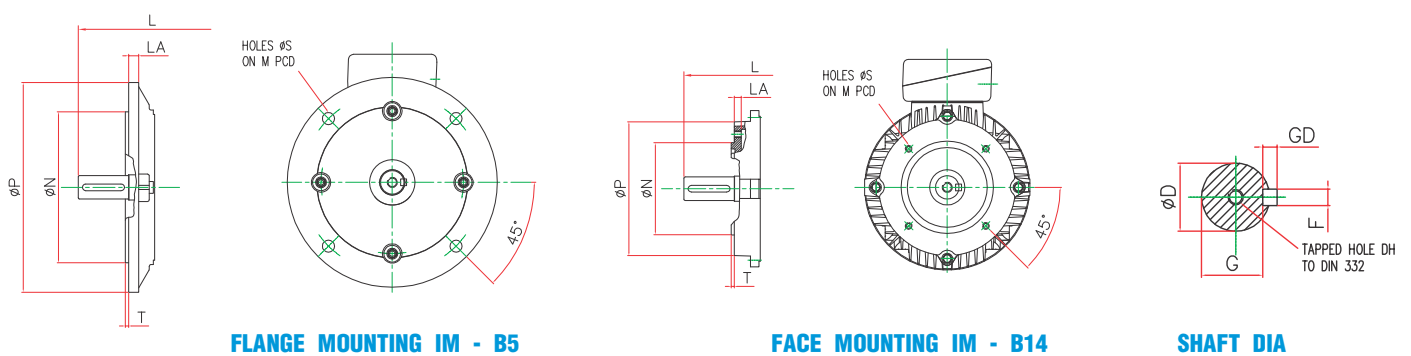

FLANGE MOUNTING IM - B5

FACE MOUNTING IM - B14

SHAFT DIA

Type	B5 MOUNTING						B14 MOUNTING						SHAFT DIMENSIONS						
	M	N	P	S	T	LA	M	N	P	S	T	LA	Type	D	E	F	G	ED	DM
GD80	165	130	200	12	3.5	12	100	80	120	M6	3	9	GD80	19	40	6	15.5	32	M6X16
GD90S/L	165	130	200	12	3.5	10	115	95	140	M8	3	9	GD90S/L	24	50	8	20	40	M8X19
GD100L	215	180	250	14.5	4	12	130	110	160	M8	3.5	12	GD100L	28	60	8	24	50	M10X22
GD112M	215	180	250	14.5	4	12	130	110	164	M8	3.5	13	GD112M	28	60	8	24	50	M10X22
GD132S/M	265	230	300	14.5	4	14	165	130	200	M10	3.5	13	GD132S/M	38	80	10	33	70	M12X28

Dimension Drawing - Three Phase Foot Mounted Cast Iron Kibosh Brake Motors

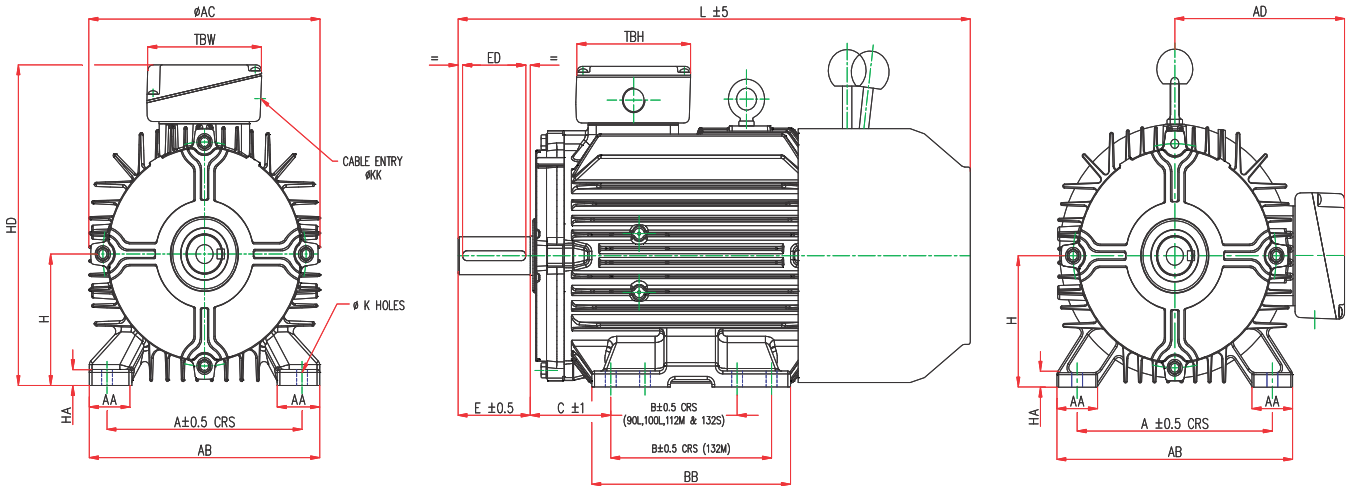

GENERAL (CAST IRON CONSTRUCTION)														Terminal Box		
Type	A	B	C	H	K	L	AA	AB	AC	AD	BB	HA	HD	TBW	TBH	KK
NG80	125	100	50	80	10	345	35	158	162	128	127	10	212	103	103	1 X 20
NG90S	140	100	56	90	10	412	35	164	180	135	166	12	225	103	103	1 X 20
NG90L	140	125	56	90	10	440	38	164	190	135	195	12	225	103	103	1 X 20
NG100L	160	140	63	100	12	502	34	184	222	162	206	12	262	106	106	1 X 20
NG112M	190	140	70	112	12	545	45	218	230	167	242	12	279	127	127	1 X 25
NG132S	216	140	89	132	12	590	47	242	275	190	220	12	322	127	127	1 X 25
NG132M	216	178	89	132	12	590	47	255	275	192	220	12	322	127	127	1 X 25

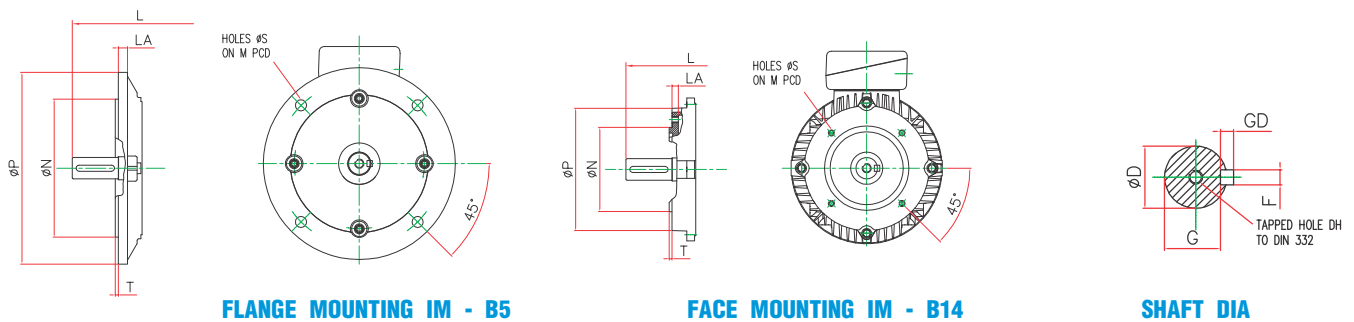

FLANGE MOUNTING IM - B5

FACE MOUNTING IM - B14

SHAFT DIA

Type	B5 MOUNTING						B14 MOUNTING						SHAFT DIMENSIONS						
	M	N	P	S	T	LA	M	N	P	S	T	LA	Type	D	E	F	G	ED	DM
NG80	165	130	200	12	3.5	12	100	80	120	M6	3	9	NG80	19	40	6	15.5	32	M6X16
NG90S/L	165	130	200	12	3.5	10	115	95	140	M8	3	9	NG90S/L	24	50	8	20	40	M8X19
NG100L	215	180	250	14.5	4	12	130	110	164	M8	3.5	12	NG100L	28	60	8	24	50	M10X22
NG112M	215	180	250	14.5	4	12	130	110	164	M8	3.5	13	NG112M	28	60	8	24	50	M10X22
NG132S/M	265	230	300	14.5	4	14	165	130	200	M10	3.5	13	NG132S/M	38	80	10	33	70	M12X28

Dimension Drawing - Three Phase Foot Mounted Cast Iron Kibosh Brake Motors

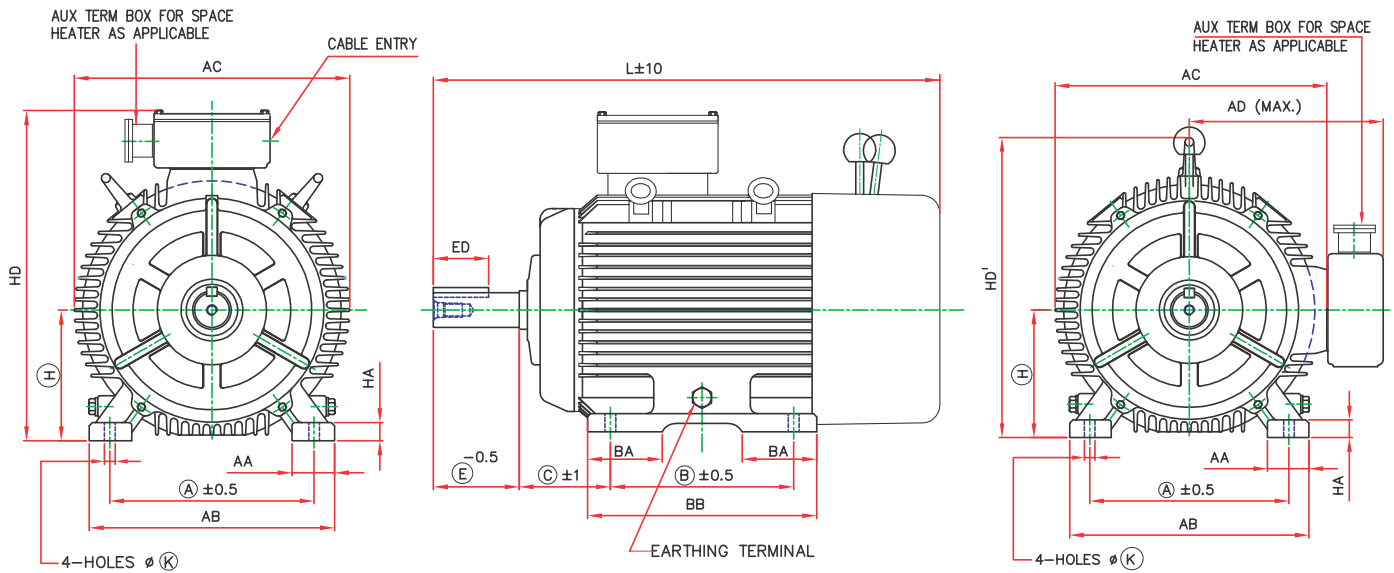

GENERAL (CAST IRON CONSTRUCTION)

Type	A	B	C	H	AA	AB	BA	BB	K	HA	AD	AC	L	HD	HD
ND160M	254	210	108	160	73	308	76	254	15	22	325	318	756	435	376
ND160L	254	254	108	160	73	308	101	298	15	22	325	318	800	435	376
ND180M	279	241	121	180	84	348	85	286	15	22	345	352	840	475	418
ND180L	279	279	121	180	84	348	106	323	15	22	345	352	878	475	418
ND200L	318	305	133	200	66	381	115	356	19	25	430	428	930	545	480

SHAFT DIMENSIONS

Frame	D	E	ED	F	G	GD	Y X DEEP
ND160M	42	110	80	12	37	8	M16X32
ND160L	42	110	80	12	37	8	M16X32
ND180M	48	110	80	14	42.5	9	M16X32
ND180L	48	110	80	14	42.5	9	M16X32
ND200L	55	110	80	16	49	10	M20X40

Y THREADED CENTRE HOLE

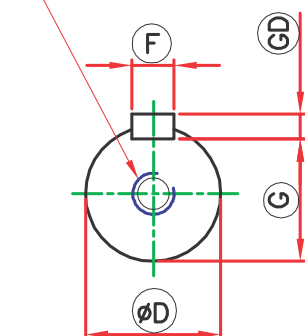

Aluminium Series Motors

FRAME	BRAKE TYPE	TORQUE (Nm)	HUB Dia.(mm)
GD80	K2	10	15
GD90	K4	20	24
GD100	K5	40	28
GD112	K6	60	28
GD132	K7 / K7D*	85/160	38

Cast Iron Motors

FRAME	BRAKE TYPE	TORQUE (Nm)	HUB Dia.(mm)
NG80	K2	10	15
NG90	K4	20	24
NG100	K5	40	28
NG112	K6	60	28
NG132	K7 / K7 D*	85/160	38
ND160M	20	260	42
ND160L	20	260	42
ND180M	25	400	48
ND180L	25	400	48
ND200L	25	400	48

Beating Details

FRAME	BRG DE	BRG NDE
GD80	6204-ZZ	6204-ZZ
GD90	6205-ZZ	6205-ZZ
GD100	6206-ZZ	6206-ZZ
GD112	6206-ZZ	6206-ZZ
GD132	6208-ZZ	6208-ZZ
NG80	6204-ZZ	6204-ZZ
NG90	6205-ZZ	6205-ZZ
NG100	6206-ZZ	6206-ZZ
NG112	6206-ZZ	6206-ZZ
NG132	6208-ZZ	6208-ZZ
ND160	6309-ZZ	6309-ZZ
ND180	6310-ZZ	6310-ZZ
ND200	6312-ZZ	6312-ZZ

*Optional





- ▶ Fast engagement of brakes
- ▶ High starting torque with low starting current
- ▶ DC and AC brake options
- ▶ No separate terminal box for rectifier and DC supply required
- ▶ Lower maintenance and enhanced liner life
- ▶ Multi Mount
- ▶ Brake Kit

Northern Region Sales Office :**New Delhi :**

3rd Floor, Express Building,
9-10, Bahadur Shah Zafar Marg,
Near ITO Crossing, New Delhi - 110 002
Phones : (011) 23460700

Jalandhar :

Nr BSF Chowk, Ladowali Road,
Jalandhar 144 001
Phones : (0181) 3051300

Lucknow :

Saran Chambers II, 3rd Floor, 5 Park Road,
Lucknow - 226 001
Phones : (0522) 4152150

Jaipur :

Church Road, P. O. Box. No. 173, Jaipur-302 001
Phones : (0141) 3018801

Eastern Region Sales Office :**Kolkata :**

50, Chowringhee Road, Kolkata - 700 071
Phones : (033) 22829681-85

Bhubaneswar :

Janpath Tower, Third Floor,
Ashok Nagar, Unit II,
Bhubaneswar - 751 009, Orissa.
Phones : (0674) 2531128

Western Region Sales Office :**Mumbai :**

Kanjur Marg (E), Mumbai-400 042.
Phones : (022) 67558590

Ahmedabad :

909-916, Sakar II, Near Ellis Bridge Police Station,
Ahmedabad - 380 006
Phones : (079) 40012000

Pune :

Premium Point, 4th Floor, Opp. Modern High School,
Jangali Maharaj Road, Pune 5.
Phones : (020) 25534675-77

Indore :

103-B, Apollo Trade Centre, 2B, Rajgarh Kothi,
Mumbai-Agra Road, Indore - 452 001.
Phones : (0731) 2498269

Nagpur :

3, West High Court Road, Lal Bahadur Shastri Chowk,
Dharampeth, Nagpur - 440 010
Phones : (0712) 2531271

Raipur :

A-201 Crystal Arcade, Shankar Nagar Road,
Near Lodhipara Square Raipur - 492001
Phones : (0771) 4019202

Southern Region Sales Office :**Chennai :**

No.3-A, MGR Salai, Kodambakkam High Road,
Nungambakkam,
Chennai - 600 034.
Phones : (044) 42247500/525

Bangalore :

J.P. Square 3rd Floor,
No-173rd Cross 5th Main,
Chamarajapet Bangalore - 560018.

Cochin :

Cherupushpam Building, 5th Floor, 330-6
Shanmugham Road, Ernakulum, Cochin - 682 031.
Phones : (0484) 2360240

Secunderabad :

4th Floor, Minerva House, 94, Sarojini Devi Road,
Secunderabad - 500 003.
Phones : (040) 40002300

Regional Service Centres :

North : 3rd Floor, Express Building, 9-10, Bahadur Shah Zafar Marg, Near ITO Crossing,
New Delhi - 110 002 Phones : (011) 23460700

East : 21, R.N.Mukherjee Road, Kolkata-700 001. Phones: (033) 22489160.

West : Kanjur Marg (E), Mumbai 400 042. Phones : (022) 67558000.

South : 3A, MGR Salai, Kodambakkam High Road, Nungambakkam, Chennai-600 034.
Phones : (044) 23651369.



NOTE : As the design and manufacture of Crompton Greaves electrical equipment are subject to constant improvement, the product supplied may differ in some details from the specifications and illustrations given in this booklet.
For more details, contact nearest Branch Office.

Crompton Greaves Limited

Website : www.cgglobal.com